

Hardware

Mailbox mounting hardware is included with all new Architectural Mailboxes posts and 4x4 wood-post adapters. If you are using an existing post, not made by Architectural Mailboxes, please reference the mounting hole diameter and pattern in Option 2 to determine the hardware you will need for installation.

Tools (not included)

One Phillips Screwdriver



One Wrench



- or -

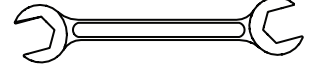

CUSTOMERS ARE REQUIRED TO CONTACT THE LOCAL POST OFFICE BEFORE INSTALLING THE MAILBOX TO ENSURE ITS CORRECT PLACEMENT AND HEIGHT AT THE STREET. GENERALLY, MAILBOXES ARE INSTALLED AT A HEIGHT OF 41-45 INCHES FROM THE ROAD SURFACE TO EITHER THE INSIDE SURFACE OF THE MAILBOX THAT THE MAIL IS PLACED ON BY THE CARRIER OR TO THE LOWEST EDGE OF MAIL ENTRY (FOR LOCKED MAIL SLOT DESIGNS) AND ARE SET BACK 6-8 INCHES FROM THE FRONT FACE OF CURB OR ROAD EDGE TO THE MAILBOX DOOR.

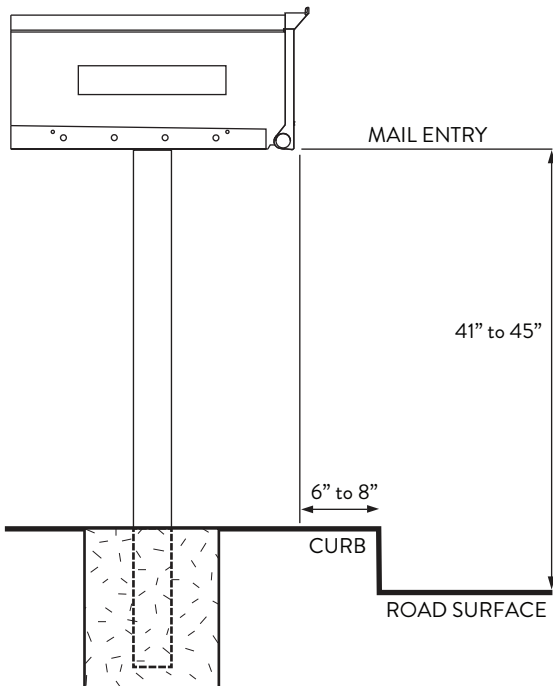

Option 1

For use with Architectural Mailboxes Patriot mounting plate or Patriot Mailbox Post Kit (sold separately)...

Bolt the mounting bracket to the sturdy post, snap the mailbox to the bracket and push onto locking tabs until engaged (no special tools required).

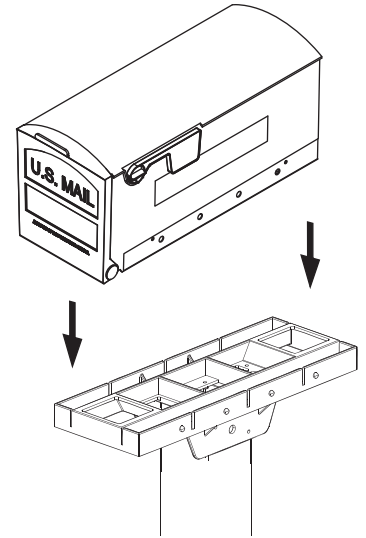

Option 2

For use with non-Architectural Mailboxes posts...

Identify if your existing post or mounting surface has a matching hole pattern with the mailbox. If there are no matching hole patterns, you will need an adapter plate or piece of wood to drill the mounting holes into. Architectural Mailboxes does **not** recommend drilling new holes in the mailbox, as that will expose untreated metal and void the product warranty. Use the drawings below for suggested bolt sizes to use with your mailbox.

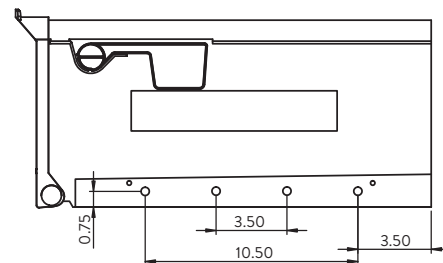

Questions, Comments, Concerns?

 www.architecturalmailboxes.com

 support@architecturalmailboxes.com

Find us on social media!



@archmailboxes